

DRAWING MADE IN THIRD ANGLE PROJECTION

THIS DRAWING IS UNPUBLISHED. RELEASED FOR PUBLICATION , 19 .
 © COPYRIGHT 19 BY AMP INCORPORATED. ALL INTERNATIONAL RIGHTS RESERVED.

LOC	DIST	P	F	ZONE	LTR	REVISIONS	DATE	APPD
AF	50				A	REV AF-5787, RELEASE PER FASR	12/7/88	(Signature)

1 CONTINUOUS STRIP ON REELS

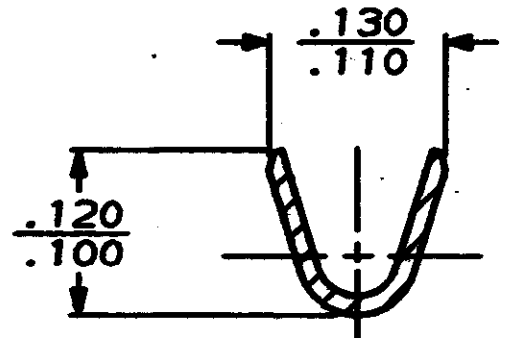
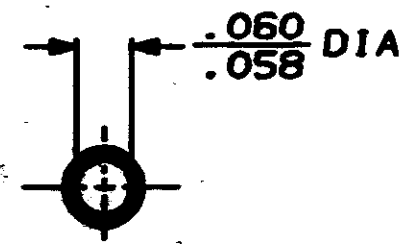
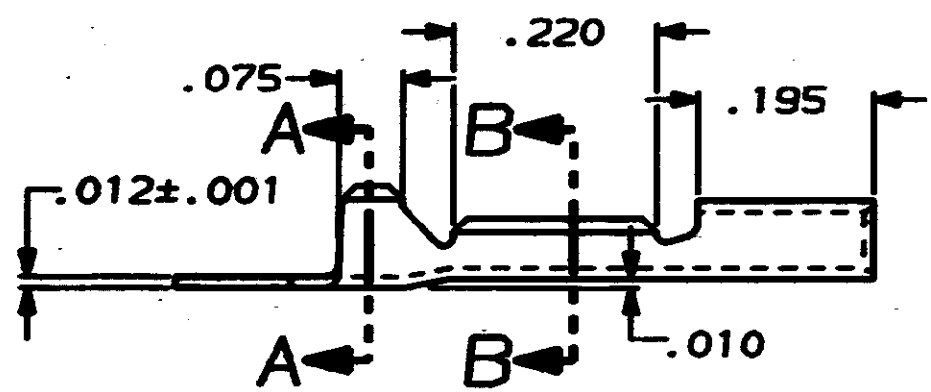
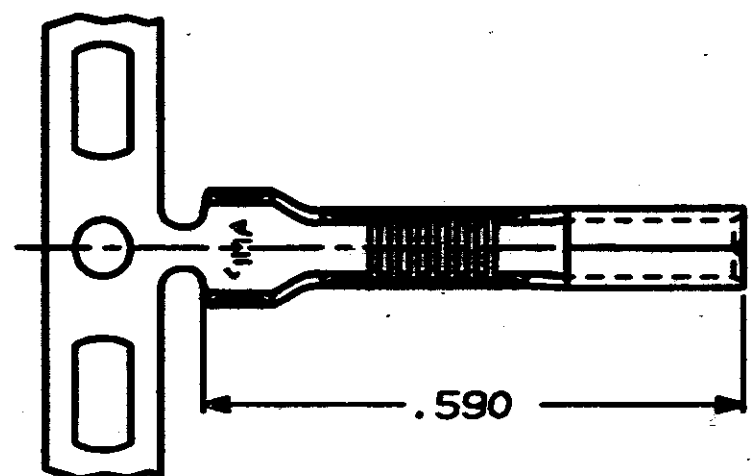

SECTION A-A
SCALE 8:1

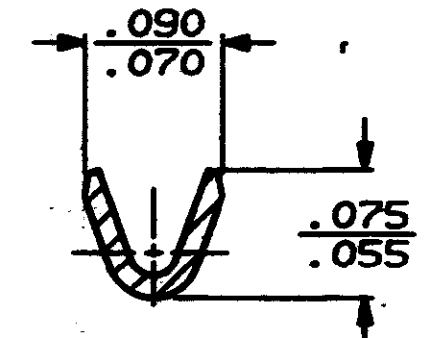

SECTION B-B
SCALE 10:1

F	.100	.260	F	.055	.041	22	DO NOT SCALE PRINT. UNLESS SPECIFIED DIMENSIONS IN INCHES TOLERANCES ON: 2 PLC DEC ± - 3 PLC DEC ± .015 ANGLES ± -	DR P. FORTNEY 7/6/88 CHK MS FEHER 7/8/88 APPD D DECKER 7/8/88 APPD TL SHUTTER 7/8/88 PRODUCT SPEC - APPLICATION SPEC - WEIGHT -	.040-.060	29-22	63506-1
					.038	24			INSULATION RANGE	MAGNET WIRE RANGE	PART NO
					.037	26			AMP AMP INCORPORATED Harrisburg, Pa. 17105		
					.035	28					
					.035	29			RECEPTACLE, PIN, .062 DIA		
TYPE	WIDTH	STRIP LENGTH	TYPE	WIDTH	±.002 HEIGHT	WIRE	MATERIAL	FINISH	SIZE	PSCH NO	DRAWING NO
INSUL BARREL CRIMP		±.015	WIRE BARREL CRIMP				#4 HARD BRASS	TIN PL .000080 MIN	B	00779	63506
								SCALE	5:1	SHEET	1 OF 1